

Specifications:

Material And Finish:  
 Insulator:LCP UL94V-0,Color:Natural  
 Contact:Phosphor Bronze  
 Solder Tabs:Brass  
 Plated:See Ordering Information

Rating:

Current Rating:1.0 Amp  
 Voltage Rating:50V AC/DC  
 Operating Temperature Range:-25~+85°C

Electrical:

Contact resistance:20m Ohm Max  
 Insulator resistance:100M ohm min.  
 Withstanding Voltage:500V AC/Minute

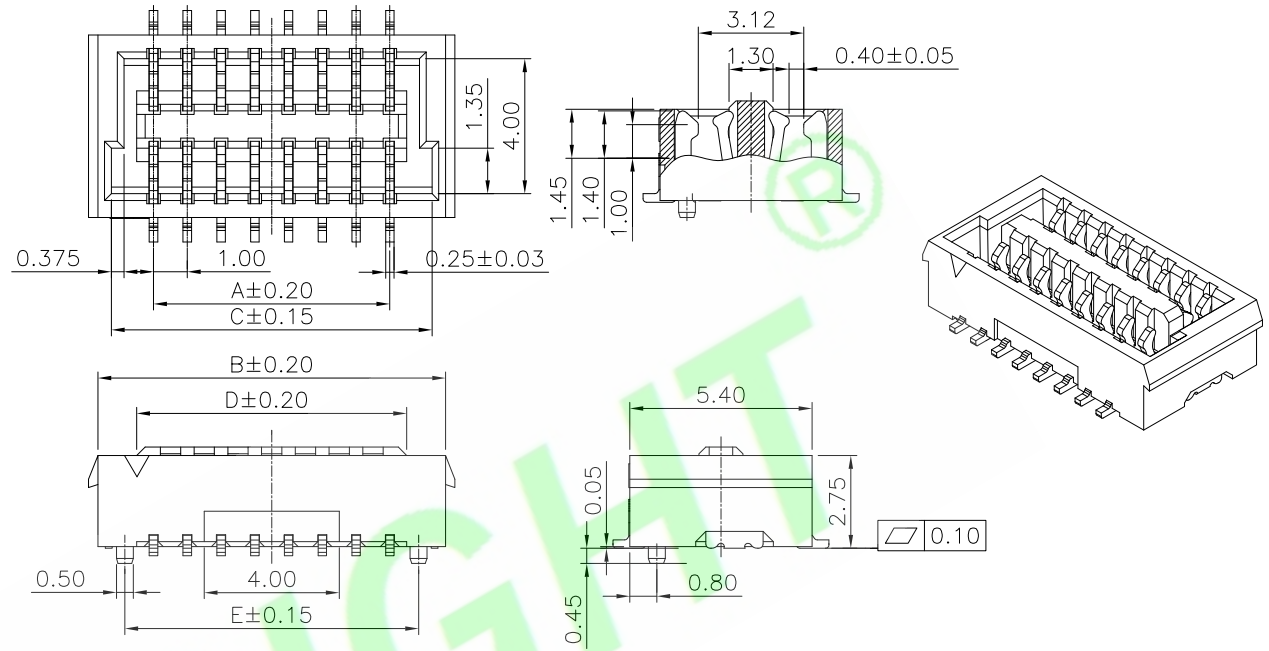

Ordering Information

A1026M-XXX-01-F

1 2 3 4 5

- 1: — Series No.
- 2: — M:SMT Type
- 3: — No. of Positions
- 4: — A:Gold Flash  
S:Matte Tin Plated
- 5: — F:W/Cap In Tape&Reel

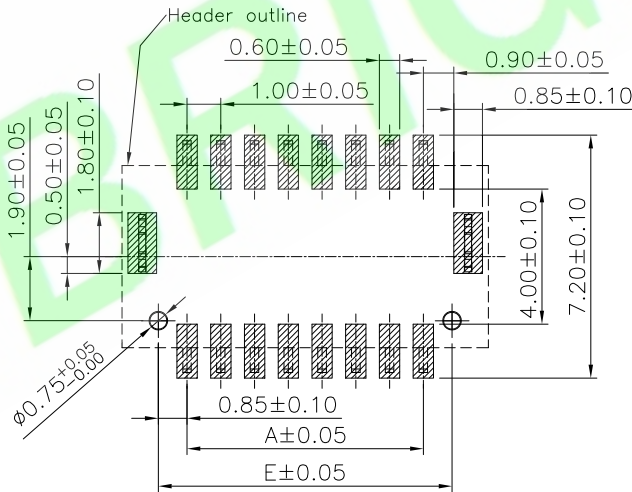

Circuits	Dimensions				
	A	B	C	D	E
10	4.00	7.30	6.50	5.00	5.70
16	7.00	10.30	9.50	8.00	8.70
20	9.00	13.30	11.50	10.00	10.70
30	14.00	17.30	16.50	15.00	15.70
40	19.00	22.30	21.50	20.00	20.70
50	24.00	27.30	26.50	25.00	25.70
60	29.00	32.30	31.50	30.00	30.70

5X				DR.BY.: Samson
4X				
3X				CHKD.: Tony
2X				
1X	ORIGINAL	Samson		APPD.: Billy
REV.	DESCRIPTION	DR.BY	ECN. NO.	

GENERAL TOLERANCE:		PART NO : A1026M-XXX-01-F	
LINEAR	ANGLES	DWG. NO.:	
X.: ±0.30	X': ±5.0°	TITLE :	
X.X: ±0.20	X.X': ±3.0°	1.0mm Pitch Wafer SMT Type	
X.XX: ±0.15	X.XX': ±2.0°	DATE: 02-Jun-2017	
X.XXX: ±0.10	X.XXX': ±1.0°		

HJBRIGHT® 东莞市華晶電子有限公司	
BRIGHT-E ELECTRONIC TECHNOLOGY LIMITED	
SHEET: 1/1	<p>THIRD ANGLE PROJECTION</p>
SCALE: 1:1	
UNIT: mm	

A4